

# Current Transformer

**Model IE53Q**

rev 032916

## CERTIFICATIONS:



ISO 9001  
Registered

Quality  
Management



**APPLICATION:**

Metering

**FREQUENCY:**

50/60 Hz.

**INSULATION LEVEL:**

720 Volts. 10 kV BIL. full wave

**APPROXIMATE WEIGHT:**

0.25 kg

**CONNECTIONS:**

Secondary terminals screw clamp up to 10mm<sup>2</sup> cable. 'Fast on' 6.3mm type. Integral Terminal Cover IP20B

**ENCLOSURE CODE:**

IP40

**INSULATION CLASS:**

Class E BS2757 IEC85

**COMPLIES WITH / APPROVALS:**

IEC60044-1:2003 / BSEN61010-1, EN60044-1

**MOUNTING HARDWARE OPTION:**

Order p/n: IE53Q-FIXING-KIT

<b>Model</b>	IE53Q
<b>Window Size</b>	20 x 6mm 21mm diameter
<b>Width</b>	45mm
<b>Height</b>	65mm
<b>Depth</b>	30mm

### MODEL IE53Q

CATALOG NUMBER	CURRENT RATIO	VA at Class 3	VA at Class 1
IE53Q-50/5	50:5	1	-
IE53Q-60/5	60:5	1.25	-
IE53Q-75/5	75:5	1.5	-
IE53Q-80/5	80:5	1.25	-
IE53Q-100/5	100:5	2.5	1.5
IE53Q-125/5	125:5	3	2.5
IE53Q-150/5	150:5	3.75	2.5
IE53Q-200/5	200:5	5	3.75
IE53Q-250/5	250:5	-	5
IE53Q-300/5	300:5	7.5	5

Note: Change the end suffix to depict required secondary. For example IE53Q-200/1.

### DIMENSIONS

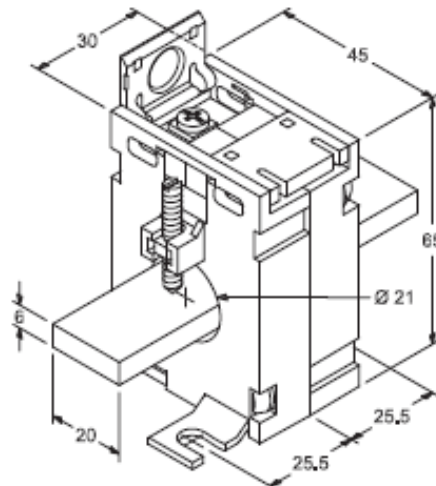

Products are manufactured in a plant whose quality management system is certified / registered as being in conformity with ISO 9001